

 sandeipartitions

OPERABLE WALL





PANEL TYPE

SC 55 - STC 35

-
- STC value 30 (STC : Sound transmission class)
 - Partition thickness of 55 mm, with a maximum height of 3000 mm.
 - For restaurants, meeting rooms, classrooms that do not require high sound reduction specifications.
 - Mempunyai nilai STC 30 (STC : Sound transmission loss)
 - Tebal partisi 55 mm, dengan tinggi maksimal 3000 mm.
 - Digunakan untuk restoran, ruang rapat, ruang kelas yang tidak membutuhkan spesifikasi pengurangan suara yang tinggi.

PANEL TYPE SC 55- STC 35

Operation Methods	Maximum Size	
	Width	Height
Cross Type		
Ordinary	1000 mm	3000 mm
Parallel		
Induction		
Center Stacking 2 Runner		
R Type		
Center Stacking 1 Runner	900 mm	3000 mm

SOUND TRANSMISSION LOSS & STC RATING

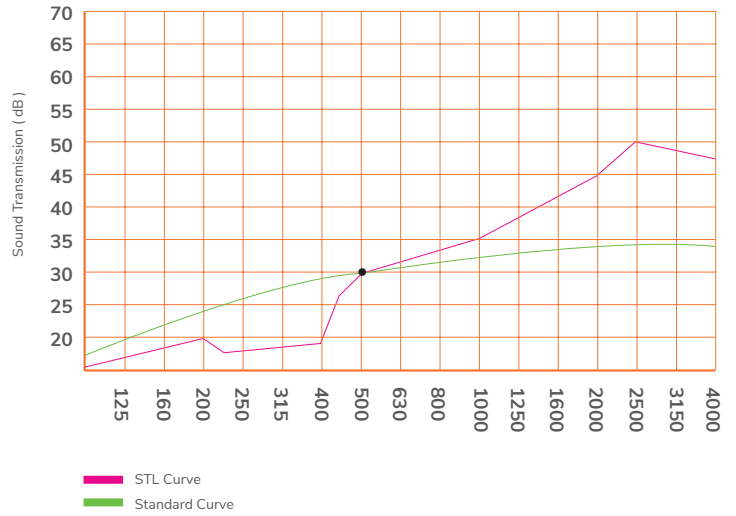

Weight Approximately : 25 kg/m²

SECTION DRAWING SC 55 - STC 35

VERTICAL SECTION DRAWING

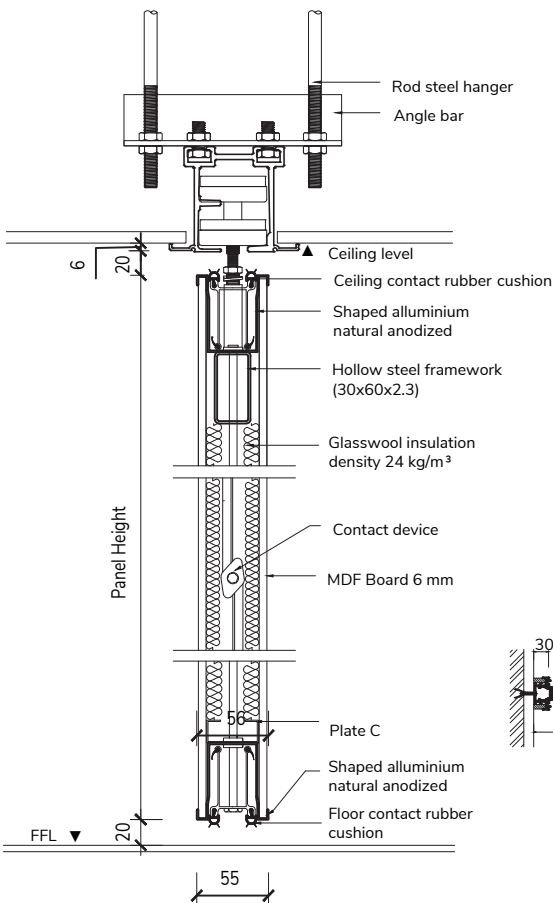

ELEVATION DRAWING

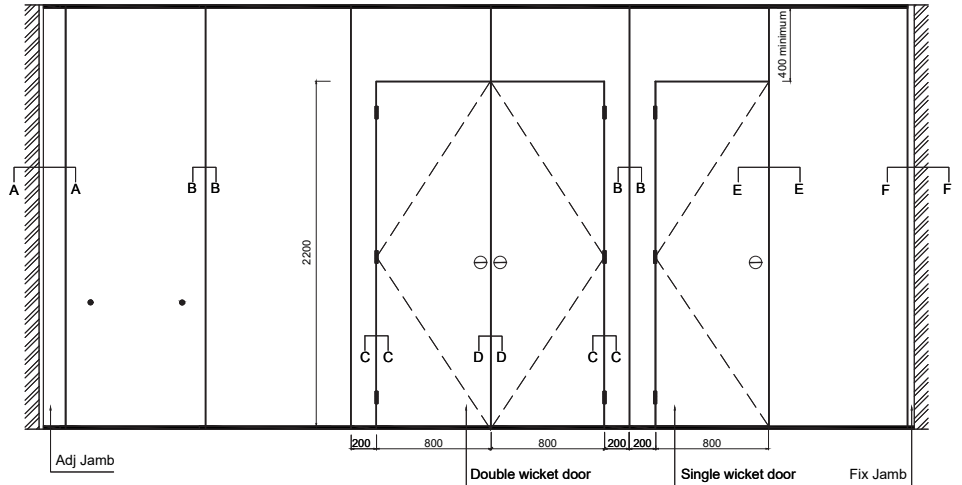

HORIZONTAL SECTION DRAWING

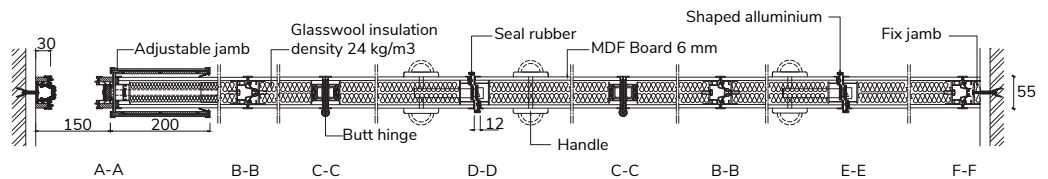



Ordinary Stacking

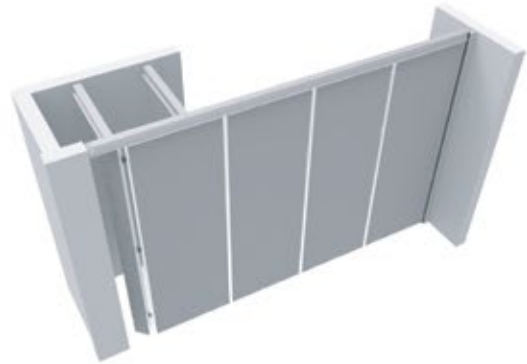

Parallel Stacking

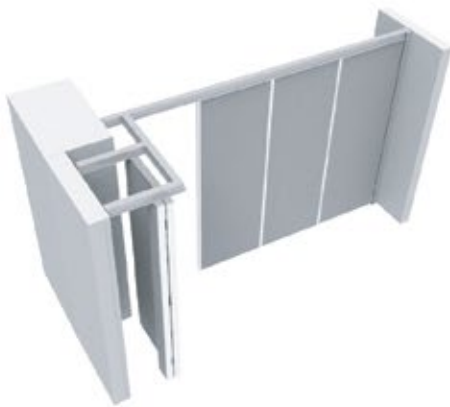

Induction Stacking



Center Stacking 2 Runners

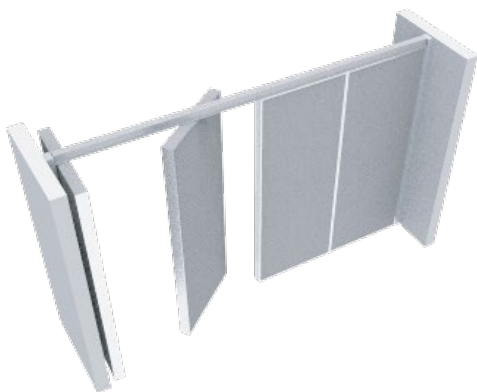

Center Stacking with 1 Runner

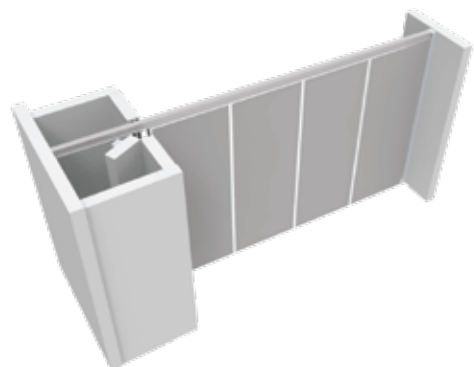



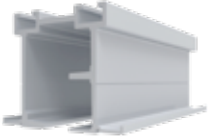

Center Stacking 1 Runner with Storage & Door

CROSS TYPE

RHF - 200 kg	<p>Rails Aluminium anodized H-base 3-5 thk</p> <p>Runner Base : MC Blue Bearing : $\phi 32$ - 2pcs H. Density PTSE - bearing cover : $\phi 51$ - 2pcs Hanger bolt : Steel $\phi 12$</p>		
--------------	--	---	---

R - TYPE

R-120 kg	<p>Rails Aluminium anodized H-base 2-4 thk</p> <p>Runner Base : Aluminium Bearing : $\phi 28$ - 4pcs Hanger bolt : Base Ring Steel $\phi 12$ Fiber guide : MC Blue</p>		
----------	--	---	---

R-300 kg	<p>Rails Aluminium anodized H-base 6 thk</p> <p>Runner Base : Aluminium Bearing : $\phi 26$ - 4pcs $\phi 30$ - 4pcs Hanger bolt : Base Ring Steel $\phi 14$</p>		
----------	--	---	---

SOUND INSULATING ABOVE CEILING

SINGLE LAYER GYPSUM

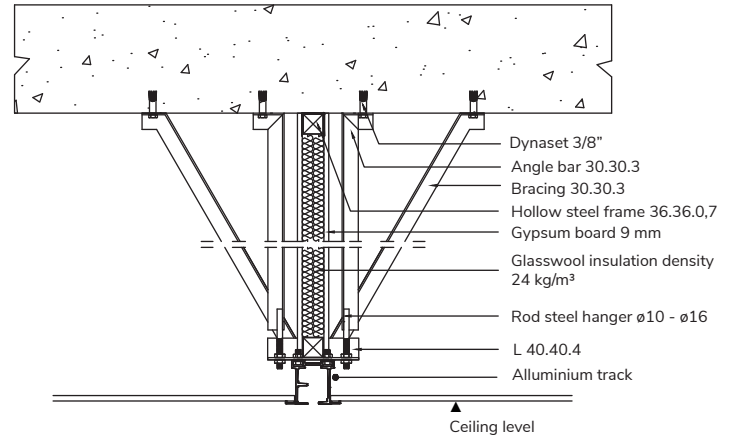
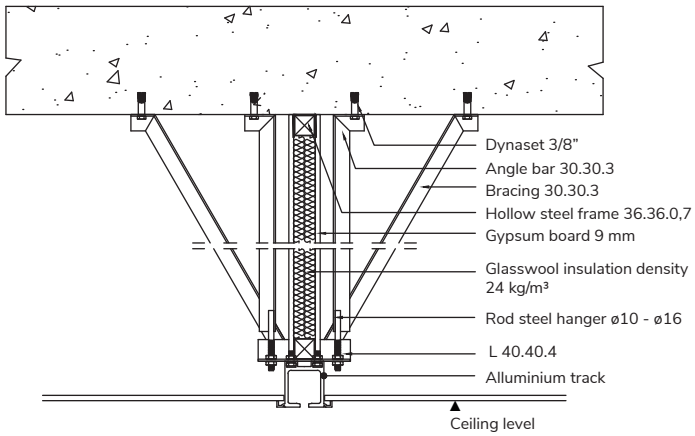

CONSTRUCTION SUPPORT

CONCRETE

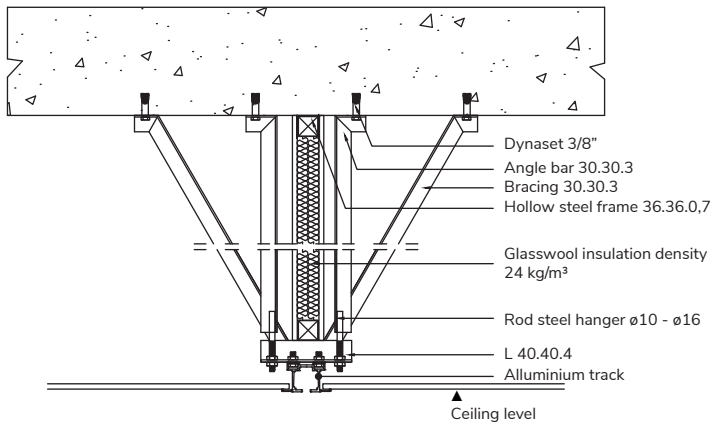

NON CONCRETE

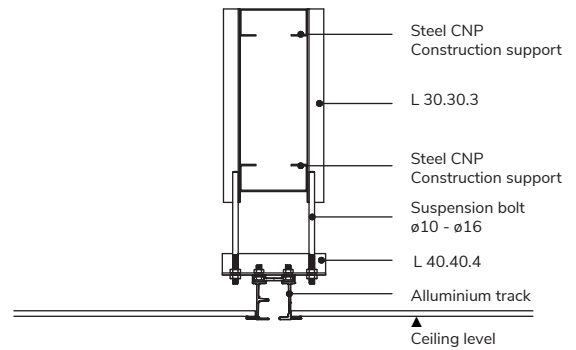

EXTRA FEATURE



Door Handle



Crank Handle

STACKING AREA OPTIONS

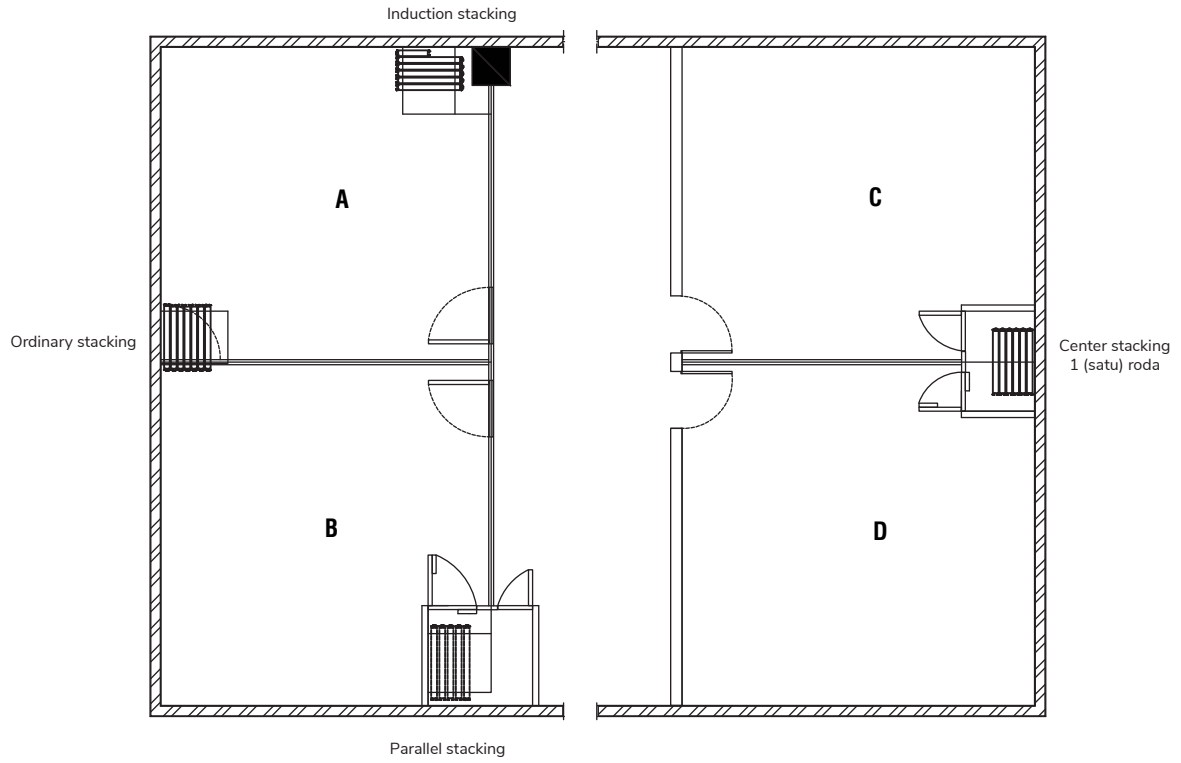

DETAIL

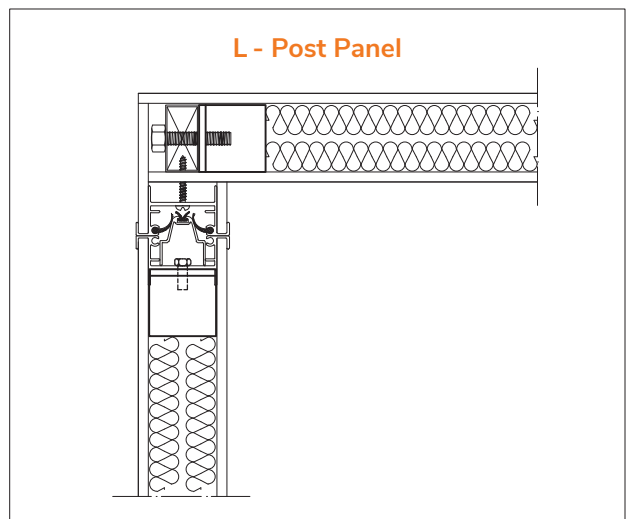
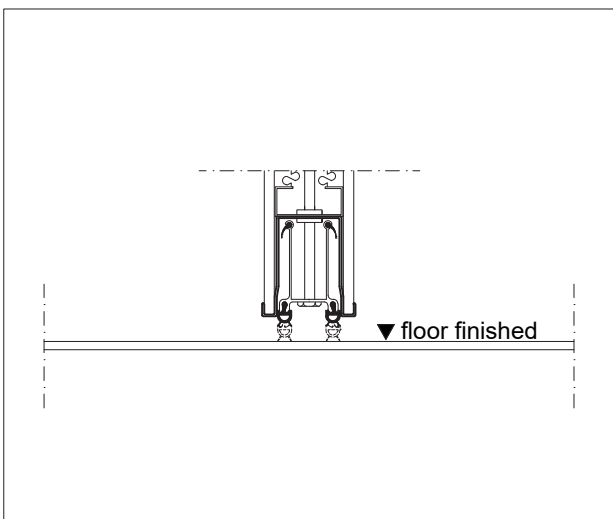
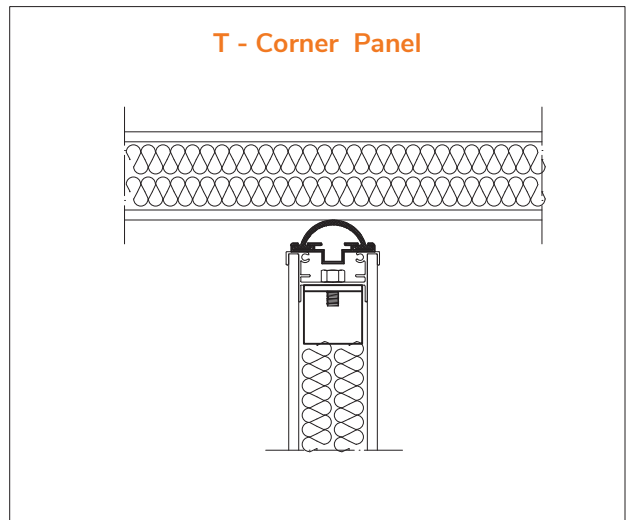
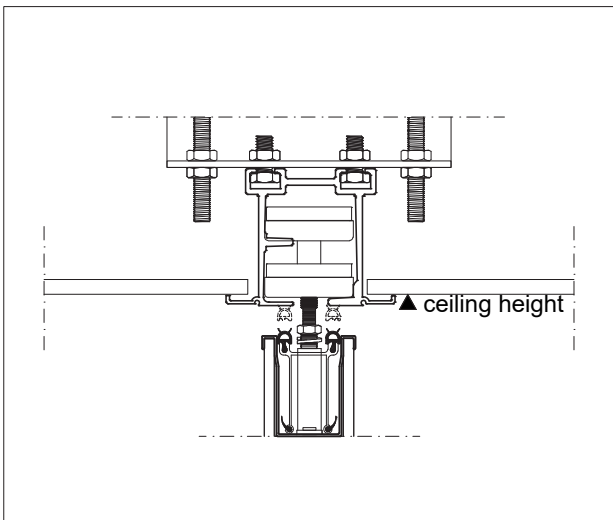

ORDINARY
STACKING
(WITH 3 STORAGE DOORS)

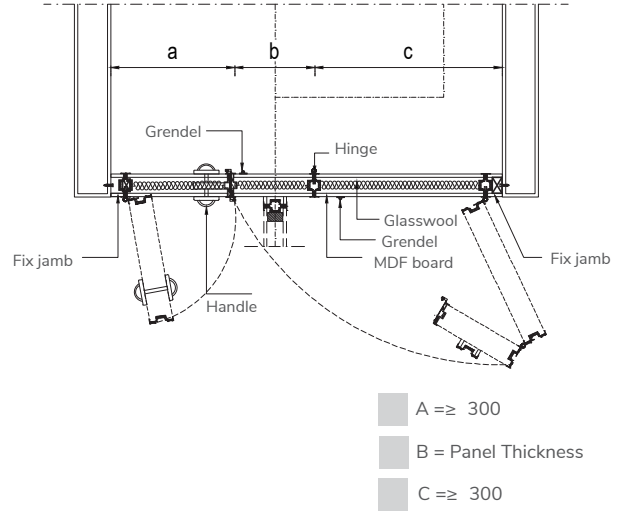
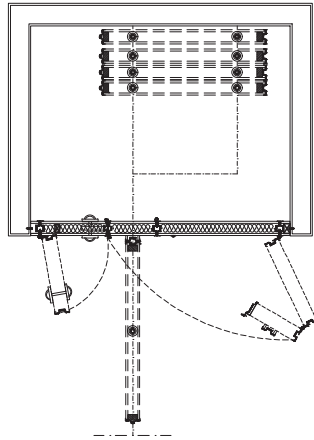

PARALLEL
STACKING
(WITH 3 STORAGE DOORS)

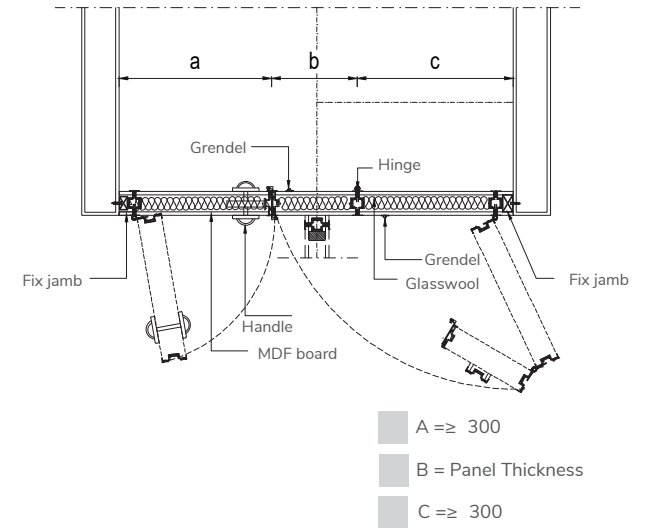
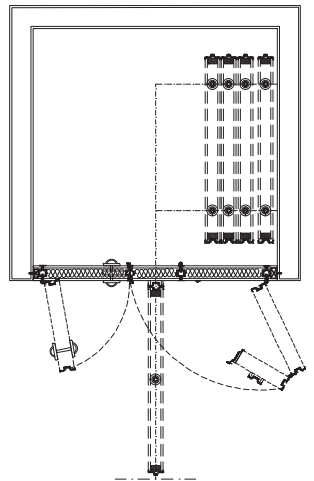

CENTER
STACKING
(WITH 3 STORAGE DOORS)

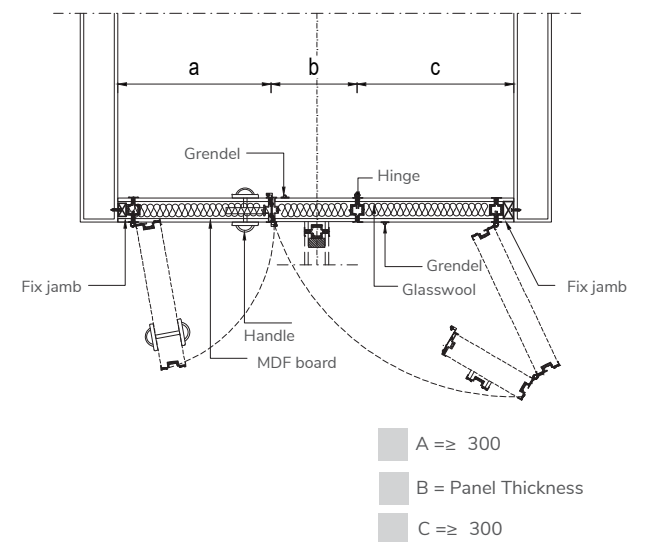
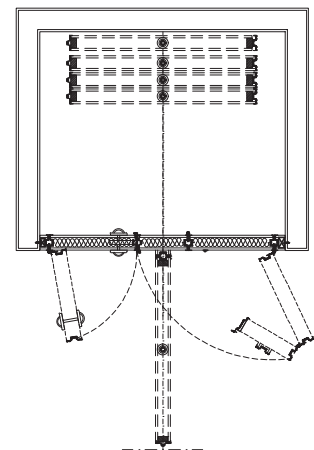

INDUCTION
STACKING
(WITH 2 STORAGE DOORS)

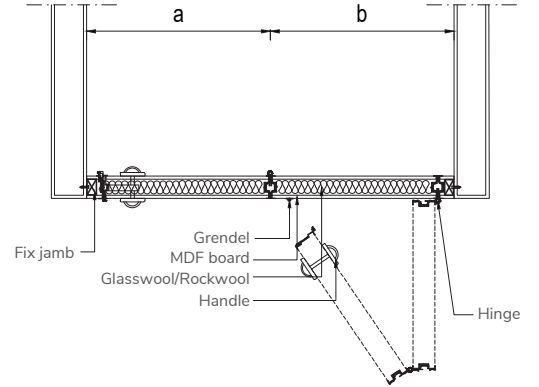
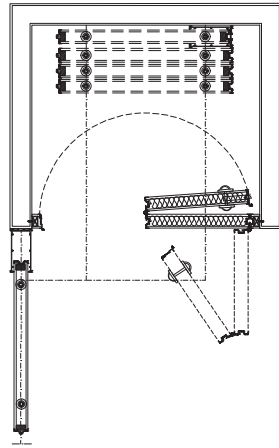

A = B ≥ 425 Max 700

INDUCTION
STACKING
(HINGE STANDART)

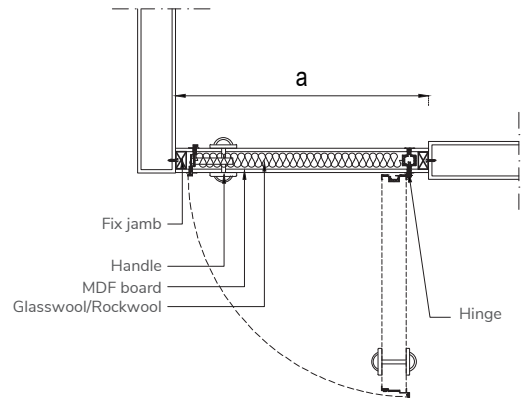
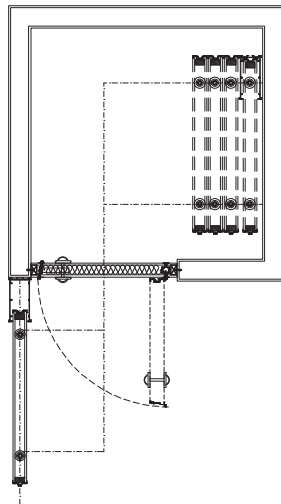

A = ≥ 800 Max 1200

INDUCTION
STACKING
(PIVOT HINGE)

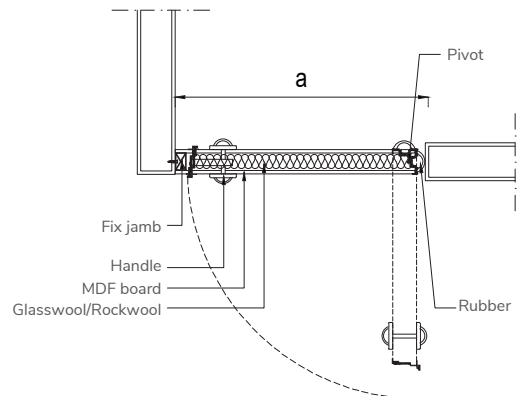
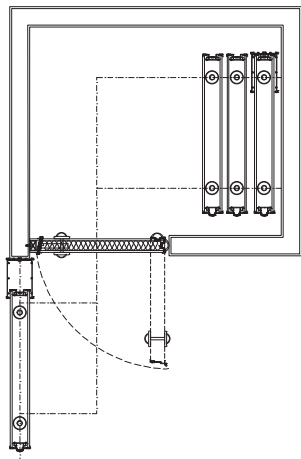

A = ≥ 800 Max 1200







www.sandei.co.id

@ sandei_official



Visit Our Website